

Air curtains ELiS C



Air curtains ELiS C

Max. range ⁽¹⁾ [m]	3
Heating capacity ⁽²⁾ [kW]	12,4–22,4
Air flow [m ³ /h]	900–2700
Weight [kg]	19,0–35,1
Colour	white ⁽³⁾
Casing	stal

⁽¹⁾ Range of vertical isothermal air stream, at 1,5 m/s velocity limit

⁽²⁾ For C-W at inlet/outlet water temperature 90/70°C, inlet air temperature 10°C

⁽³⁾ Similar to RAL 9016



Application:

ELiS C air curtains are dedicated for public buildings like markets, sports halls, stores, restaurants, etc. ELiS C units are designed for horizontal installation directly above the door openings, which height does not exceed 3 m.

Available types of units:

Available in 3 lengths: 1 m, 1,5 m or 2 m.

Available in 2 versions:

-  W – curtain with water heat exchanger
-  E – curtain with electric heaters

Technical data

	ELiS C-W-100	ELiS C-E-100	ELiS C-W-150	ELiS C-E-150	ELiS C-W-200	ELiS C-E-200
Power supply [V/Hz]	230/50	3x400/50	230/50	3x400/50	230/50	3x400/50
Power consumption [kW]	0,14	6,5	0,21	10,0	0,26	13,0
Current consumption [A]	0,65	9,4	0,95	14,5	1,2	18,7
IP	21/F					
Connection ["]	¾"	–	¾"	–	¾"	–
Air flow [m ³ /h]	1400	1300	2100	1950	3000	2700
Acoustic pressure level [dB(A)] ⁽¹⁾	46,5	46,5	48,5	48,5	50,5	50,5
Max. heating water temperature [°C]	90	–	90	–	90	–
Max. operating pressure [MPa]	1,2	–	1,2	–	1,2	–
Air temperature rise (ΔT) [°C] ⁽²⁾	31	15	32	15	32	15
Weight of unit [kg]	19,0	14,5	27,5	19,9	35,1	25,1
Weight of unit filled with water [kg]	19,9	–	28,8	–	36,9	–
Range [m] ⁽³⁾	3					

⁽¹⁾ Acoustic pressure level measured for optimum installation height, on second step of efficiency, in the room with medium capability of sound absorption, capacity 500 m³, at distance of 3 m from the unit

⁽²⁾ For C-W at inlet/outlet water temperature 90/70°C and inlet air temperature 10°C / for C-E at inlet air temperature 10°C

⁽³⁾ Range of vertical isothermal air stream, at velocity limit above 1,5 m/s



Dimensions

C-W-100

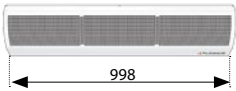

C-W-150

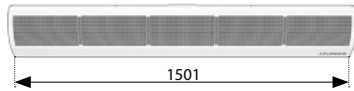

C-W-200

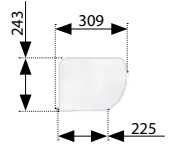
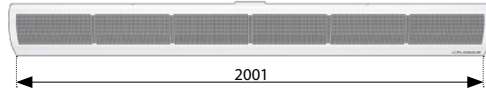

C-E-100

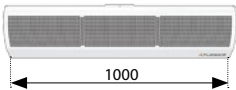

C-E-150

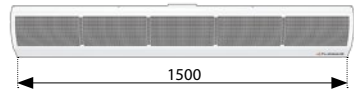

C-E-200

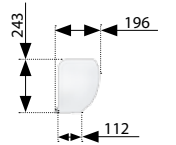
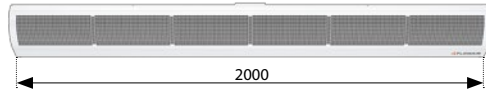

Installation



Connection diagram

Air curtain ELiS C TS REGULATION

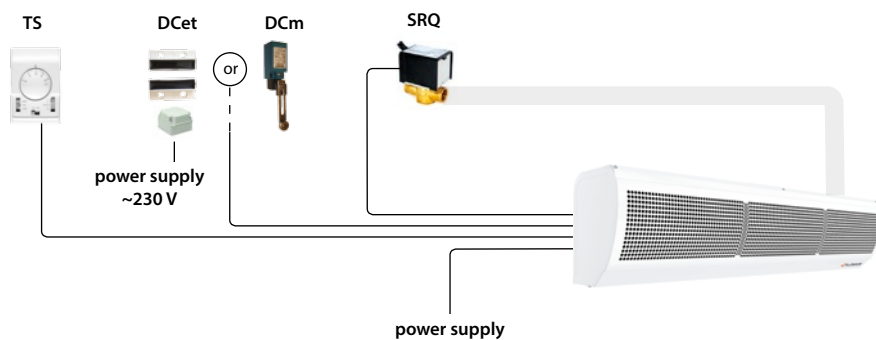

ELEMENTS:

- TS – 3-step fan speed controller with thermostat
- DCet – magnetic door sensor with relay box
- DCm – mechanical door sensor
- SRQ – valve with actuator

Examples of installation

ELiS C air curtains are dedicated for public buildings like markets, sports halls, stores, restaurants, etc.



Heating capacities

ELiS C WITH WATER HEAT EXCHANGER

ELiS C-W-100

Tp1	V	PT	Qw	Δpw	Tp2	PT	Qw	Δpw	Tp2
°C	m³/h	kW	l/h	kPa	°C	kW	l/h	kPa	°C
Tw1/Tw2 = 90/70°C					Tw1/Tw2 = 80/60°C				
0	1050/1250/1400	14,2/15,8/17,0	625/698/749	15,4/18,8/21,3	40,0/37,5/36,0	12,2/13,6/14,6	537/599/643	12,0/14,7/16,7	34,5/32,5/31,0
5		13,3/14,8/15,9	587/655/703	13,7/16,7/19,0	42,5/40,0/38,5	11,3/12,7/13,6	498/556/596	10,5/12,8/14,5	37,0/35,0/33,5
10		12,4/13,8/14,9	547/611/655	12,1/14,7/16,7	45,0/42,5/41,0	10,4/11,6/12,5	458/512/549	9,1/11,0/12,5	39,5/37,5/36,5
15		11,5/12,8/13,8	507/566/608	10,5/12,9/14,6	47,0/45,0/44,0	9,5/10,6/11,4	418/467/501	7,7/9,4/10,6	41,5/40,0/39,0
20		10,6/11,8/12,7	467/522/560	9,1/11,1/12,6	49,5/47,5/46,5	8,6/9,6/10,3	378/422/453	6,4/7,8/8,9	44,0/42,5/41,5
Tw1/Tw2 = 70/50°C					Tw1/Tw2 = 60/40°C				
0	1050/1250/1400	10,3/11,5/12,3	449/501/538	9,0/11,0/12,5	29,0/27,0/26,0	8,3/9,3/9,9	361/403/432	6,4/7,8/8,8	23,5/22,0/21,0
5		9,4/10,5/11,2	410/457/491	7,7/9,3/10,6	31,5/29,5/28,5	7,4/8,2/8,8	322/359/385	5,2/6,3/7,1	26,0/24,5/23,5
10		8,5/9,4/10,1	370/413/443	6,4/7,8/8,8	33,5/32,0/31,5	6,5/7,2/7,7	282/314/337	4,1/5,0/5,6	28,0/27,0/26,5
15		7,5/8,4/9,0	330/368/395	5,2/6,3/7,2	36,0/35,0/34,0	5,5/6,2/6,6	241/269/288	3,1/3,8/4,3	30,5/29,5/29,0
20		6,6/7,4/7,9	289/323/346	4,1/5,0/5,7	38,5/37,5/36,5	4,6/5,1/5,5	199/222/238	2,2/2,7/3,1	32,5/32,0/31,5

ELiS C-W-150

Tp1	V	PT	Qw	Δpw	Tp2	PT	Qw	Δpw	Tp2
°C	m³/h	kW	l/h	kPa	°C	kW	l/h	kPa	°C
Tw1/Tw2 = 90/70°C					Tw1/Tw2 = 80/60°C				
0	1600/1850/2100	21,9/24,1/26,1	968/1062/1150	16,6/19,6/22,7	40,5/38,5/36,5	18,9/20,8/22,5	832/912/988	13,0/15,3/17,7	35,0/33,0/31,5
5		20,6/22,6/24,4	908/996/1078	14,8/17,5/20,2	43,0/41,0/39,5	17,6/19,3/20,8	772/846/916	11,3/13,4/15,4	37,5/35,5/34,5
10		19,2/21,1/22,8	847/930/1006	13,0/15,4/17,8	45,5/43,5/42,0	16,2/17,7/19,2	710/779/843	9,8/11,5/13,3	40,0/38,0/37,0
15		17,8/19,5/21,1	786/862/933	11,4/13,4/15,5	47,5/46,0/44,5	14,8/16,2/17,5	649/712/770	8,3/9,8/11,3	42,0/40,5/39,5
20		16,4/18,0/19,5	724/794/860	9,8/11,6/13,4	50,0/48,5/47,0	13,4/14,6/15,8	587/643/696	6,9/8,2/9,4	44,5/43,0/42,0
Tw1/Tw2 = 70/50°C					Tw1/Tw2 = 60/40°C				
0	1600/1850/2100	15,9/17,5/18,9	696/764/826	9,7/11,5/13,2	29,5/28,0/26,5	12,9/14,1/15,3	561/615/666	6,9/8,1/9,3	24,0/22,5/21,5
5		14,5/15,9/17,2	636/697/754	8,3/9,8/11,2	32,0/30,5/29,0	11,5/12,6/13,6	500/548/593	5,6/6,6/7,6	26,0/25,0/24,0
10		13,1/14,4/15,6	574/630/681	6,9/8,1/9,4	34,0/33,0/32,0	10,0/11,0/11,9	438/480/519	4,4/5,2/6,0	28,5/27,5/26,5
15		11,7/12,8/13,9	512/562/608	5,6/6,6/7,6	36,5/35,5/34,5	8,6/9,4/10,2	375/411/445	3,4/4,0/4,5	31,0/30,0/29,5
20		10,3/11,3/12,2	449/493/533	4,5/5,2/6,0	39,0/38,0/37,0	7,1/7,8/8,5	311/341/368	2,4/2,8/3,3	33,0/32,5/32,0

ELiS C-W-200

Tp1	V	PT	Qw	Δpw	Tp2	PT	Qw	Δpw	Tp2
°C	m³/h	kW	l/h	kPa	°C	kW	l/h	kPa	°C
Tw1/Tw2 = 90/70°C					Tw1/Tw2 = 80/60°C				
0	2300/2600/3000	31,4/34,0/37,1	1386/1498/1638	39,4/45,4/53,5	40,5/38,5/36,5	27,2/29,4/32,1	1194/1290/1411	30,9/35,6/41,9	35,0/33,5/31,5
5		29,5/31,9/34,8	1301/1406/1538	35,1/40,5/47,6	43,0/41,0/39,5	25,2/27,3/29,8	1108/1198/1310	27,0/31,1/36,6	37,5/36,0/34,5
10		27,5/29,8/32,5	1215/1313/1436	31,0/35,7/42,0	45,0/43,5/42,0	23,3/25,1/27,5	1022/1105/1207	23,3/26,9/31,6	40,0/38,5/37,0
15		25,6/27,6/30,2	1128/1219/1333	27,1/31,2/36,7	47,5/46,0/44,5	21,3/23,0/25,1	935/1010/1104	19,9/22,9/26,8	42,0/41,0/39,5
20		23,6/25,5/27,9	1040/1125/1229	23,4/26,9/31,7	50,0/48,5/47,0	19,3/20,8/22,8	847/915/1000	16,6/19,1/22,4	44,5/43,5/42,0
Tw1/Tw2 = 70/50°C					Tw1/Tw2 = 60/40°C				
0	2300/2600/3000	22,9/24,8/27,1	1003/1084/1185	23,3/26,8/31,5	29,5/28,0/26,5	18,7/20,2/22,0	813/879/961	16,6/19,1/22,4	24,0/23,0/22,0
5		21,0/22,7/24,8	917/991/1084	19,8/22,8/26,8	32,0/30,5/29,5	16,7/18,0/19,7	727/786/859	13,6/15,6/18,3	26,5/25,5/24,5
10		19,0/20,5/22,4	830/897/981	16,6/19,1/22,4	34,5/33,0/32,0	14,7/15,9/17,3	639/691/755	10,8/12,4/14,5	29,0/28,0/27,0
15		17,0/18,3/20,0	743/802/877	13,6/15,6/18,2	36,5/35,5/34,5	12,6/13,6/14,9	550/595/650	8,3/9,5/11,1	31,0/30,5/29,5
20		14,9/16,1/17,6	654/706/772	10,8/12,4/14,6	39,0/38,0/37,0	10,6/11,4/12,5	460/497/543	6,0/6,9/8,1	33,5/33,0/32,0

V – air flow
PT – air flow
Tp1 – inlet air temperature
Tp2 – outlet air temperature

Tw1 – inlet water temperature
Tw2 – outlet water temperature
Qw – water stream flow in the heat exchanger
Δpw – water pressure drop in the heat exchanger